

850C

C SERIES II

SPECIFICATIONS



Engine

850C

Type	John Deere 6081A with altitude-compensating turbocharger; aftercooled
Engine power	185 SAE net hp (138 kW) / 192 SAE gross hp (143 kW) @ 1,800 rpm
Cylinders	6
Displacement	494 cu. in. (8.1 L)
Fuel consumption, typical	4.6 to 7.0 gal./hr. (17.4 to 26.5 L/h)
Maximum net torque	601 lb.-ft. (815 Nm) @ 1,300 rpm
Lubrication	pressure system with full-flow spin-on filter and oil-to-water cooler
Air cleaner	dual stage dry type with safety element, precleaner, and underhood restriction indicator
Electrical system	24 volt with 45-amp alternator
Cooling fan	blower

Transmission

automatic, dual-path, hydrostatic drive; load sensing feature automatically adjusts speed and power to match changing load conditions; each individually controlled track is powered by a variable displacement piston pump and motor combination; travel speeds (forward and reverse) infinite to 6.8 mph (0 to 11 km/h); ground-speed selection buttons on single-lever steering and direction control; independently selectable reverse speed ratios 80%, 100%, 115%, or 130% of forward ground speed; decelerator pedal controls ground speed to dead stop

Final Drives

double-reduction, planetary final drives transfer torque loads over three gear sets; mounted independently of track frames and dozer push frames for isolation from shock loads

Steering

single-lever steering, direction, and ground-speed control provides smooth metered turns; full power turns, counterrotation, and infinitely variable track speeds provide unlimited maneuverability and optimal control; hydrostatic steering system eliminates steering clutches and brakes

Brakes

hydrostatic (dynamic) braking stops machine when the direction/steering control lever is moved to neutral, the decelerator is depressed to the end of travel, or the brake pedal is depressed

Automatic Parking Brake

this safety feature engages wet, multiple-disk brakes automatically whenever the engine stops, the operator applies the brake pedal, or the neutral start lever lock is in stop position; machine cannot be operated with brake applied

Hydraulic System

System type	open center
Pressure, system relief	2,250 psi (15 514 kPa)
Pump type	gear
Flow	44 gpm (166 L/min.) @ 2,100 rpm
Filter, return oil	10 micron
Control	standard – T-bar, two function / with All-Hydraulic (PAT) dozer blade – T-bar, three function
Cylinders	heat-treated, chrome-plated, polished cylinder rods with hardened steel (replaceable bushings) pivot pins
Cooling	oil-to-air heat exchanger

Capacities (U.S.)

850C LT

850C WT

850C WXLT

850C LGP

Fuel tank with lockable cap	92 gal. (348 L)	92 gal. (348 L)	92 gal. (348 L)	92 gal. (348 L)
Cooling system with recovery tank	9 gal. (34 L)	9 gal. (34 L)	9 gal. (34 L)	9 gal. (34 L)
Engine oil with spin-on filter	34 qt. (32.2 L)	34 qt. (32.2 L)	34 qt. (32.2 L)	34 qt. (32.2 L)
Final drive (each)				
1st reduction	3.25 gal. (12.3 L) Semi-U / 4.35 gal. (16.5 L) PAT	4.35 gal. (16.5 L) Semi-U / 10.0 gal. (37.9 L) PAT	10.0 gal. (37.9 L) PAT	10.0 gal. (37.9 L) Semi-U / 10.0 gal. (37.9 L) PAT
2nd reduction	3.25 gal. (12.3 L)	3.25 gal. (12.3 L)	3.25 gal. (12.3 L)	3.25 gal. (12.3 L)
Hydraulic system reservoir	21 gal. (79.5 L)	21 gal. (79.5 L)	21 gal. (79.5 L)	21 gal. (80 L)
Hydrostatic transmission reservoir	27 gal. (102.2 L)	27 gal. (102.2 L)	27 gal. (102.2 L)	27 gal. (103 L)

Undercarriage

seven-roller track frame with front and rear track guides and sprocket guard; John Deere Dura-Trax™ features deep-heat-treated, sealed, and lubricated track links and through-hardened, sealed, and lubricated rollers for maximum wear resistance; sprockets are segmented; extreme-duty shoes are available (on some models) for severe applications

Chain	sealed and lubed	sealed and lubed	sealed and lubed	sealed and lubed
Grouser width	24 in. (610 mm)	30 in. (762 mm)	30 in. (762 mm)	38 in. (965 mm) base / 34 in. (865 mm) PAT
Shoes, each side	40	40	43	43
Ground contact area	5,184 sq. in. (33 445 cm ²)	6,480 sq. in. (41 806 cm ²)	7,260 sq. in. (46 838 cm ²)	9,196 sq. in. (59 329 cm ²) base / 8,228 sq. in. (53 084 cm ²) PAT
Ground pressure	7.8 psi (53.8 kPa) Semi-U / 8.2 psi (56.5 kPa) PAT	6.3 psi (43.4 kPa) Semi-U / 6.7 psi (46.2 kPa) PAT	6.1 psi (42.0 kPa) PAT	4.6 psi (31.7 kPa) Semi-U / 5.4 psi (37.2 kPa) PAT
Ground clearance, minimum				
With single-bar grouser (excluding grouser height)	16.0 in. (406 mm)	16.0 in. (406 mm)	16.0 in. (406 mm)	16.0 in. (406 mm)
With swamp shoe (including grouser height)				19.0 in. (483 mm) base
Length of track on ground	108 in. (2743 mm)	108 in. (2743 mm)	121 in. (3073 mm)	121 in. (3073 mm)
Track gauge, standard	74 in. (1880 mm) Semi-U / 82 in. (2083 mm) PAT	80 in. (2032 mm) Semi-U / 88 in. (2235 mm) PAT	88 in. (2235 mm) PAT	88 in. (2235 mm) Semi-U / 92 in. (2337 mm) PAT
Oscillation at front roller	6 degrees, or 9.1 in. (231 mm) Semi-U / 6 degrees, or 9.7 in. (246 mm) PAT	6 degrees, or 9.0 in. (229 mm) Semi-U / 7 degrees, or 10.8 in. (274 mm) PAT	6 degrees, or 10.4 in. (264 mm) PAT	7 degrees, or 12.5 in. (318 mm) Semi-U / 7 degrees, or 12.8 in. (325 mm) PAT
Track rollers each side	7	7	7	7
Track pitch	8 in. (203 mm)	8 in. (203 mm)	8 in. (203 mm)	8 in. (203 mm)

SAE Operating Weights**850C LT****850C WT****850C WXL T****850C LGP**

Base weights were computed for units with standard equipment, rollover protective structures, full fuel tanks, and 175-lb. (79 kg) operators.

All-Hydraulic (PAT) Dozer	42,418 lb. (19 241 kg)	43,366 lb. (19 671 kg)	44,369 lb. (20 126 kg)	44,582 lb. (20 222 kg)
Semi-U (High Production)	40,485 lb. (18 402 kg)	41,070 lb. (18 668 kg)	N/A	42,048 lb. (19 113 kg)

Refer to the Attachment Guide or see your dealer for details regarding Semi-U (Low Profile), Straight, and Mechanical Angle blades for the 850C LT and Straight blade for the 850C LGP.

Blade Weights

Includes push beams, trunnion mounts, straight end bits, C-frames, angle and tilt cylinders where applicable.

All-Hydraulic (PAT) Dozer	6,094 lb. (2764 kg)	6,253 lb. (2836 kg)	6,389 lb. (2898 kg)	6,521 lb. (2958 kg)
Semi-U (High Production)	5,289 lb. (2404 kg)	5,495 lb. (2498 kg)	N/A	5,636 lb. (2562 kg)

Refer to the Attachment Guide or see your dealer for details regarding Semi-U (Low Profile), Straight, and Mechanical Angle blades for the 850C LT and Straight blade for the 850C LGP.

Blade Capacities

All-Hydraulic (PAT) Dozer	5.15 cu. yd. (3.94 m ³)	5.50 cu. yd. (4.21 m ³)	5.50 cu. yd. (4.21 m ³)	5.78 cu. yd. (4.42 m ³)
Semi-U (High Production)	7.44 cu. yd. (5.69 m ³)	8.06 cu. yd. (6.16 m ³)	N/A	7.14 cu. yd. (5.46 m ³)

Refer to the Attachment Guide or see your dealer for details regarding Semi-U (Low Profile), Straight, and Mechanical Angle blades for the 850C LT and Straight blade for the 850C LGP.

Optional or Special Equipment

Complete push beam assemblies for straight or semi-U blades, rakes, Stingers®, etc.	2,083 lb. (947 kg)	2,192 lb. (996 kg)	N/A	2,298 lb. (1045 kg)
Complete PAT dozer C-frame assembly	3,141 lb. (1425 kg)	3,141 lb. (1425 kg)	3,277 lb. (1487 kg)	3,277 lb. (1487 kg)
PAT dozer blade weight	2,953 lb. (1339 kg)	3,112 lb. (1411 kg)	3,112 lb. (1411 kg)	3,244 lb. (1471 kg)
Tracks – Dura-Trax™ lubricated chain with split master link				
Single-bar grousers				
22-in. (560 mm) moderate duty	5,762 lb. (2619 kg)	5,762 lb. (2619 kg)	N/A	N/A
22-in. (560 mm) extreme duty	6,273 lb. (2851 kg)	6,273 lb. (2851 kg)	N/A	N/A
24-in. (610 mm) moderate duty	6,035 lb. (2743 kg)**	6,035 lb. (2743 kg)	N/A	N/A
24-in. (610 mm) extreme duty	6,665 lb. (3029 kg)*§	6,665 lb. (3029 kg)§	N/A	7,164 lb. (3256 kg)
30-in. (760 mm) moderate duty		6,824 lb. (3102 kg)*	7,336 lb. (3335 kg)	N/A
34-in. (865 mm) moderate duty				7,776 lb. (3535 kg)**
38-in. (965 mm) moderate duty§				8,349 lb. (3795 kg)*§
Swamp shoe – 36.5-in. (928 mm)				11,492 lb. (5224 kg)§
Cab with pressurizer and heater/air conditioner	806 lb. (366 kg)	806 lb. (366 kg)	806 lb. (366 kg)	806 lb. (366 kg)
ROPS	1,430 lb. (650 kg)*	1,430 lb. (650 kg)*	1,430 lb. (650 kg)*	1,430 lb. (650 kg)*
Rock guard, center section	443 lb. (201 kg)*	443 lb. (201 kg)*	N/A	N/A
Drawbar, rigid	112 lb. (51 kg)**	112 lb. (51 kg)	112 lb. (51 kg)	112 lb. (51 kg)*
Drawbar, extended rigid	282 lb. (128 kg)*	282 lb. (128 kg)*	282 lb. (128 kg)*	282 lb. (128 kg)
Limb risers (ROPS canopy and cab)	550 lb. (250 kg)	550 lb. (250 kg)	550 lb. (250 kg)	550 lb. (250 kg)
Rear screen (ROPS canopy)	75 lb. (34 kg)	75 lb. (34 kg)	75 lb. (34 kg)	75 lb. (34 kg)
Rear screen (cab with air conditioner)	110 lb. (50 kg)	110 lb. (50 kg)	110 lb. (50 kg)	110 lb. (50 kg)
Side screens (ROPS canopy and cab)	70 lb. (32 kg)	70 lb. (32 kg)	70 lb. (32 kg)	70 lb. (32 kg)
Cylinder hose guards	65 lb. (30 kg)	65 lb. (30 kg)	65 lb. (30 kg)	65 lb. (30 kg)
Prescreener guard	15 lb. (7 kg)	15 lb. (7 kg)	15 lb. (7 kg)	15 lb. (7 kg)
Track cleaner bars, front	275 lb. (125 kg)	N/A	N/A	N/A
Track cleaner bars, rear	450 lb. (205 kg)	N/A	N/A	N/A
Tank guard	1,100 lb. (500 kg)	1,100 lb. (500 kg)	1,100 lb. (500 kg)	1,100 lb. (500 kg)
Lift cylinder guards	120 lb. (55 kg)	120 lb. (55 kg)	120 lb. (55 kg)	120 lb. (55 kg)
Extreme-service bottom guard	350 lb. (159 kg)	350 lb. (159 kg)	350 lb. (159 kg)	350 lb. (159 kg)
Heavy-duty transverse case cover with doors	944 lb. (429 kg)*	944 lb. (429 kg)**	944 lb. (429 kg)**	944 lb. (429 kg)
Grille housing mounted counterweight	1,592 lb. (724 kg)§	1,592 lb. (724 kg)§	1,592 lb. (724 kg)§	1,592 lb. (724 kg)§

* Included in SAE operating weight.

** Also included in SAE operating weight – 850C with PAT option.

§ Not available with PAT option.

Dimensions

	A Overall height to roof		B Tread depth with single-bar grousers		C Ground clearance with grousers		
	Overall height to exhaust stack		Moderate duty	Extreme duty	Tread depth with swamp shoes		
850C LT	124.0 in. (3151 mm)	124.8 in. (3170 mm)	2.6 in. (65 mm)	2.8 in. (72 mm)		16 in. (406 mm)	
850C WT	124.0 in. (3151 mm)	124.8 in. (3170 mm)	2.6 in. (65 mm)			16 in. (406 mm)	
850C WXLT	124.0 in. (3151 mm)	124.8 in. (3170 mm)	2.6 in. (65 mm)			16 in. (406 mm)	
850C LGP	124.0 in. (3151 mm)	124.8 in. (3170 mm)	2.6 in. (65 mm)		3.7 in. (93 mm)	16 in. (406 mm)	
	D Blade width	E Blade height	F Blade lift height	G Blade digging depth	H Blade tilt (uses tilt jack)	I Overall length with blade	J Overall width with blade angled
850C LT							
All-Hydraulic (PAT) Dozer	146.0 in. (3708 mm)	48.3 in. (1227 mm)	38.0 in. (962 mm)	33.4 in. (849 mm)	19.0 in. (482 mm)	203.1 in. (5160 mm)**	131.6 in. (3343 mm)
Semi-U (High Production)	128.3 in. (3259 mm)	56.5 in. (1435 mm)	43.3 in. (1100 mm)	20.2 in. (513 mm)	28.7 in. (730 mm)	207.1 in. (5262 mm)*	N/A
*Optional extended drawbar adds 10.1 in. (253 mm). **Optional extended drawbar adds 8.9 in. (223 mm).							
850C WT							
All-Hydraulic Dozer (PAT)	158.0 in. (4013 mm)	48.3 in. (1227 mm)	38.0 in. (962 mm)	33.4 in. (849 mm)	20.5 in. (522 mm)	203.1 in. (5160 mm)**	142.4 in. (3618 mm)
Semi-U (High Production)	140.0 in. (3556 mm)	56.5 in. (1435 mm)	43.3 in. (1100 mm)	20.2 in. (513 mm)	34.6 in. (878 mm)	207.1 in. (5262 mm)***	N/A
Optional extended drawbar adds 8.9 in. (223 mm). *Optional extended drawbar adds 7 in. (176 mm).							
850C WXLT							
All-Hydraulic Dozer (PAT)	158.0 in. (4013 mm)	48.3 in. (1227 mm)	40.7 in. (1034 mm)	35.2 in. (893 mm)	20.5 in. (522 mm)	218.5 in. (5553 mm)**	142.4 in. (3618 mm)
**Optional extended drawbar adds 8.9 in. (223 mm).							
850C LGP							
<i>Semi-U (Low Profile) and Straight blades available through Custom Engineering.</i>							
All-Hydraulic (PAT) Dozer	168.0 in. (4267 mm)	48.3 in. (1227 mm)	40.7 in. (1034 mm)	35.2 in. (893 mm)	21.8 in. (554 mm)	218.5 in. (5553 mm)**	152.0 in. (3860 mm) / 144 in. (3658 mm)#
Semi-U (High Production)	156.6 in. (3978 mm)	43.8 in. (1113 mm)	42.5 in. (1080 mm)	16.9 in. (429 mm)	37.0 in. (940 mm)	222.5 in. (5651 mm)**	N/A
**Optional extended drawbar adds 8.9 in. (223 mm). #With L/R angle cylinder pins removed at blade.							
	K Blade angle	L Cut reach	M Width over track	N Cast reach	O Cutting edge angle		
850C LT							
All-Hydraulic (PAT) Dozer	25 degrees	4.5 in. (113 mm)	106 in. (2692 mm)	21.2 in. (538 mm)	60 degrees		
850C WT							
All-Hydraulic (PAT) Dozer	25 degrees	3.9 in. (98 mm)	118 in. (2997 mm)	20.5 in. (523 mm)	60 degrees		
850C WXLT							
All-Hydraulic (PAT) Dozer	25 degrees	3.9 in. (98 mm)	118 in. (2997 mm)	20.5 in. (523 mm)	60 degrees		
850C LGP							
All-Hydraulic (PAT) Dozer	25 degrees	4.5 in. (113 mm)	126 in. (3200 mm)	21.2 in. (538 mm)	60 degrees		
Drawbar Pull				850C			
Maximum				72,000 lb. (320 kN)			
At 1.2 mph (1.9 km/h)				35,200 lb. (156 kN)			
At 2.0 mph (3.2 km/h)				25,300 lb. (112 kN)			

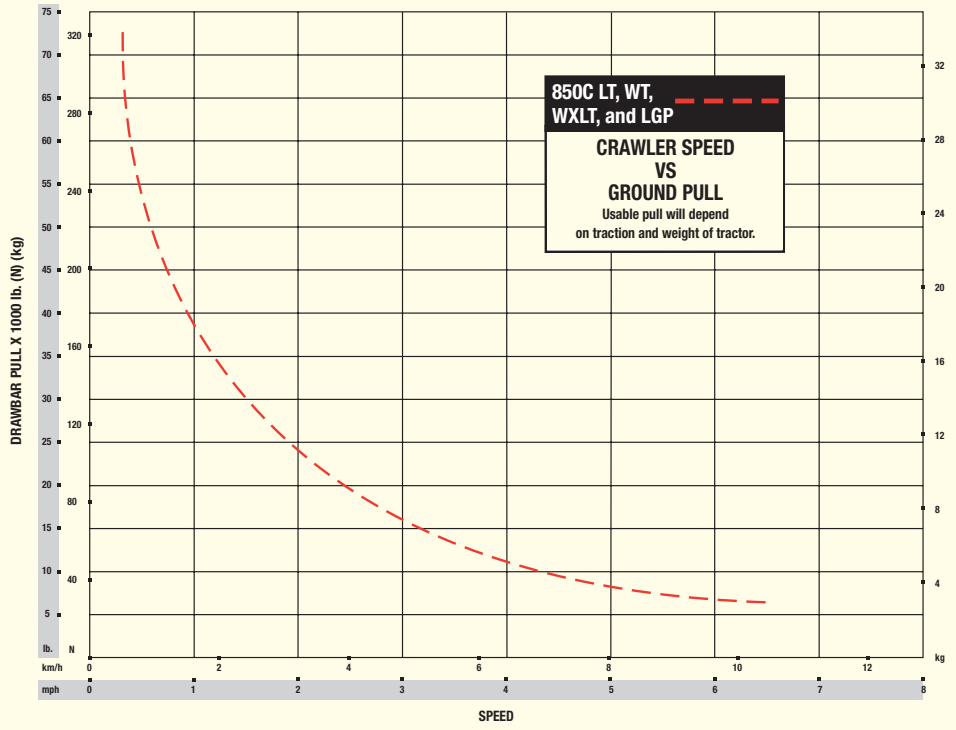
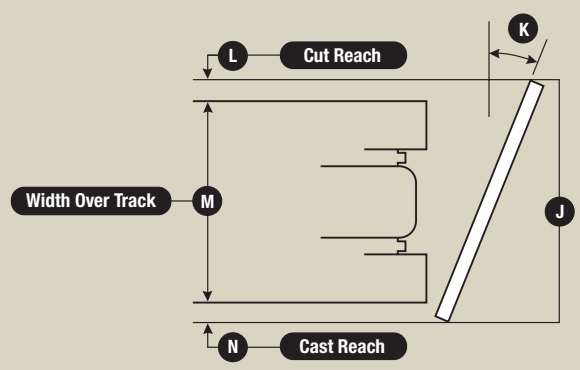
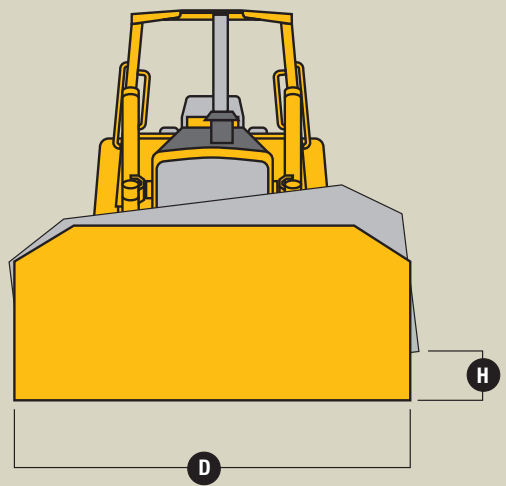
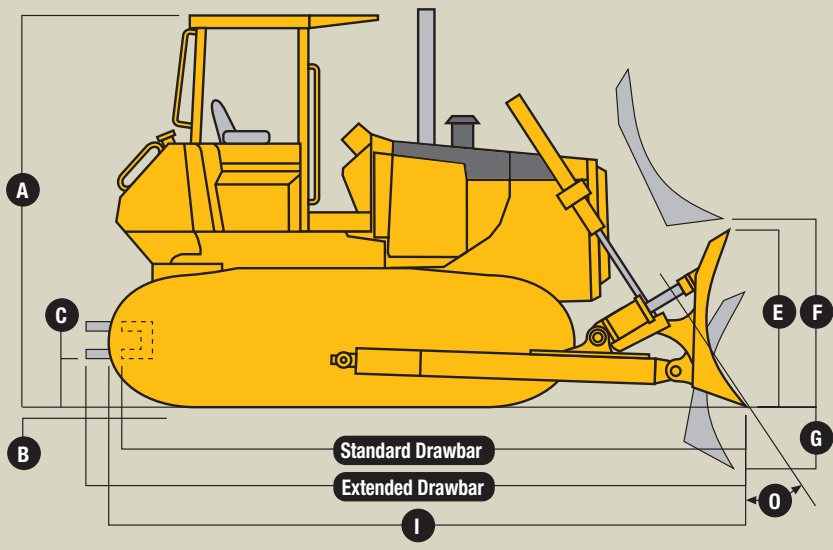

850C Series II Dozer

Key: ● Standard equipment ▲ Optional or special equipment

See your John Deere dealer for further information.

LT WT WXLT LGP Engine

- ● ● ● Air cleaner, dual-stage aspirated type
- ● ● ● Air cleaner restriction indicator
- ● ● ● Blower fan
- ● ● ● Coolant recovery tank
- ● ● ● Electric ether start aid
- ● ● ● Enclosed safety fan guard (conforms to SAE J1308)
- ● ● ● Engine coolant -34°F (-37°C)
- ● ● ● Oil-to-water engine oil cooler
- ● ● ● Precleaner
- ● ● ● Spin-on fuel filter
- ● ● ● Trash-resistant radiator
- ● ● ● Turbocharger
- ● ● ● Underhood muffler with vertical exhaust stack
- ● ● ● Water separator
- ▲ ▲ ▲ ▲ Engine coolant heater, 1,000 watts, 120 volts
- ▲ ▲ ▲ ▲ Prescreeener guard
- ▲ ▲ ▲ ▲ Radiator sand screen
- ▲ ▲ ▲ ▲ Reversible fan
- ▲ ▲ ▲ ▲ Chrome exhaust stack

Power Train

- ● ● ● Automatic applied, hydrostatic-released park brake, pedal operated
- ● ● ● Oil-to-air transmission cooler
- ● ● ● Dual-path hydrostatic transmission
- ● ● ● Guard, built-in final drive seal
- ● ● ● Transmission neutral lock with starter safety switch
- ● ● ● Transmission diagnostic test ports
- ▲ ▲ ▲ ▲ Remote transmission diagnostic test ports
- ▲ ▲ ▲ ▲ Winch drive

Electrical

- ● ● ● Batteries, two, 160-min. reserve capacity, 950 CCA
- ● ● ● Bypass start safety cover at starter
- ● ● ● Master electrical disconnect switch, lockable

Hydraulic System

- ● ● ● Oil-to-air hydraulic cooler
- ● ● ● Lift cylinders
- ● ● ● "O" ring face seal fittings
- ● ● ● Quick-drop hydraulic valve (Semi-U blade) (optional with All-Hydraulic [PAT] dozer blade)
- ▲ ▲ ▲ ▲ All-Hydraulic (PAT) dozer blade with grille "up-loop" plumbing
- ● ● ● Two-spool hydraulic system
- ● ● ● Three-spool hydraulic system (standard with PAT blade)
- ▲ ▲ ▲ ▲ Four-spool hydraulic system (with PAT blade)
- ▲ ▲ ▲ ▲ Auxiliary hydraulic lines to rear
- ▲ ▲ ▲ ▲ Oil sampling test kit

Undercarriage

- ● ● ● Chain guides
- ● ● ● Front idler and bolt-on sprocket chain guides
- ● ● ● Sealed and lubricated chain
- ● ● ● Oscillating track-frame system
- ● ● ● Pinned front track-frame crossbar system

LT WT WXLT LGP Undercarriage (continued)

- ▲ ▲ ▲ 22-in. (560 mm) moderate-duty single-bar grouser tracks, Dura-Trax™ lubricated chain with split master link
- ▲ ▲ ▲ 22-in. (560 mm) extreme-duty single-bar grouser tracks, Dura-Trax lubricated chain with split master link
- ▲ ▲ 24-in. (610 mm) moderate-duty single-bar grouser tracks, Dura-Trax lubricated chain with split master link (for 850C LT)
- ▲ ▲ ▲ 24-in. (610 mm) extreme-duty single-bar grouser tracks, Dura-Trax lubricated chain with split master link (N/A for 850C PAT blade)
- ● ● 30-in. (760 mm) moderate-duty single-bar grouser tracks, Dura-Trax lubricated chain with split master link
- ▲ ▲ 34-in. (865 mm) moderate-duty single-bar grouser tracks, Dura-Trax lubricated chain with split master link (with PAT blade)
- ▲ ▲ 38-in. (965 mm) moderate-duty single-bar grouser tracks, Dura-Trax lubricated chain with split master link (for 850C LGP Semi-U blade)
- ▲ ▲ ▲ 36.5-in. (928 mm) swamp shoe tracks, Dura-Trax lubricated chain with split master link (N/A with PAT blade)
- ▲ ▲ ▲ Bolt-on full-length rock guards

Lights

- ▲ ▲ ▲ ▲ Two front driving/working and one rear working halogen, 33,000 candlepower (375 737 lux each)

Operator's Station

- ● ● ● Built-in diagnostics - Fault code retrieval / Onboard diagnostics for monitors, controller(s), wiring, gauges, sensors, etc.
- ● ● ● Built-in Operator's Manual storage compartment and manual
- ▲ ▲ ▲ ▲ Cab - Air conditioning, 33,000 Btu* / Fresh air intake heater/pressurizer, 400 CFM, 40,000 Btu/hr. (11.7 kW) (conforms to SAE J1503, J1535D) / Front window and two door windshield wipers/washers
- ● ● ● Deluxe suspension vinyl seat - Adjustable armrests, thigh support, backrest, height/weight, and fore-aft (conforms to SAE J899)
- ● ● ● Deluxe suspension cloth seat
- ● ● ● Deluxe air suspension vinyl and cloth seat
- ● ● ● Electronic monitor system with audible and visual warning - Air restriction / Coolant temperature / Engine oil pressure / Ether injection on / Fasten seat belt / Hydraulic filter restriction / Low alternator voltage / Transmission filter restriction / Transmission malfunction / Transmission return to neutral / Transmission temperature
- ● ● ● Engine rpm digital display (selectable)
- ● ● ● Floormat

LT WT WXLT LGP Operator's Station (continued)

- ● ● ● Fuel gauge, electric, illuminated
- ● ● ● Ground-speed decelerator (engine and transmission)
- ● ● ● Headliner for ROPS/FOPS
- ● ● ● Horn, electric (conforms to SAE J994, J1446)
- ● ● ● Hourmeter, electric, illuminated (selectable)
- ● ● ● Interior-mounted rearview mirror (conforms to SAE J985)
- ● ● ● Key start switch with electric fuel shutoff
- ● ● ● Lunch-box storage
- ● ● ● Modular design ROPS/FOPS canopy (conforms to SAE J1040)
- ● ● ● Parking brake, single-lever activation
- ▲ ▲ ▲ ▲ Protection package, full vehicle - Brush screens, heavy-duty / Guards, tank protection / Limb risers, arched
- ● ● ● Reverse ratio - user selectable at 80%, 100%, 115%, or 130% of forward speed
- ● ● ● Seat belt, 3 in. (76 mm), with retractors (conforms to SAE J386)
- ● ● ● Single-lever steering, direction, and ground-speed control with selectable ground-speed and horn controls integrated in "T" handle
- ● ● ● Tool storage, lockable
- ● ● ● Voltmeter digital display (selectable)

Overall Vehicle

- ● ● ● Front tow hook
- ● ● ● Heavy-duty, hinged, bar-type grille
- ● ● ● Perforated engine side shields
- ● ● ● Rear service doors, lockable
- ● ● ● Reverse alarm - Switchable to 97 dB(A) or 111 dB(A) (conforms to SAE J994, J1446)
- ● ● ● Vandal protection - Engine access door / Fuel tank cap / Rear service doors / Instrument panel
- ▲ ▲ ▲ ▲ Cupped end bits (except All-Hydraulic [PAT] dozer blades*)
- ▲ ▲ ▲ ▲ Straight end bits
- ● ● ● All-Hydraulic (PAT) dozer blade (included in SAE operating weight)
- ● ● ● Semi-U (High Production) dozer blade (included in SAE operating weight)
- ● ● ● Tilt cylinder hose protection
- ▲ ▲ ▲ ▲ Blade trash rack
- ▲ ▲ ▲ ▲ Environmental fluid drains
- ▲ ▲ ▲ ▲ Extended rigid drawbar with pin for pull-type implements (for 850C LT included in SAE operating weight)
- ▲ ▲ ▲ Heavy-duty transverse case cover (standard for WT with PAT blade)
- ▲ ▲ ▲ ▲ Perforated hood for trash environments
- ▲ ▲ ▲ ▲ Rigid drawbar with pin (standard for LT and WT with PAT blade) (for 850C WT, 850C LGP included in SAE operating weight)
- ▲ ▲ ▲ ▲ Trash bars front and rear
- ▲ ▲ ▲ ▲ Grille housing mounted counterweight (N/A with PAT blade)



JOHN DEERE

Net engine power is with standard equipment including air cleaner, exhaust system, alternator, and cooling fan, at standard conditions per SAE J1349 and DIN 6270B, using No. 2-D fuel at 35 API gravity. No derating is required up to 10,000-ft. (3050 m) altitude. Gross power is without cooling fan.

Also available: winches, fair-leads, log arches, skidding grapples, trash packages, landfill protection packages, cable plows, side booms, field-installed cab for ROPS, ROPS heater, and fire suppression systems.

Specifications and design subject to change without notice. Wherever applicable, specifications are in accordance with SAE standards. Except where otherwise noted, these specifications are based on units with rollover protective structures, full fuel tanks, 175-lb. (79 kg) operators, and standard equipment.

